

RECOGNITION OF LACNIC

November 28 th , 2001

1) The region of coverage should meet the scale to be defined by ICANN, given the need to avoid global address fragmentation.

LACNIC will operate in a large geographical region of a continental size.

This region will be served by a RIR established under one management and in one operational location. The establishment of this unique RIR in our region clearly will avoid:

- Fragmentation of address space allocated to our region;
- Difficulty for coordination and operation between the RIR;
- Avoid confusion for the community within our region.

The internal administrative and membership structure of LACNIC will ensure that none of the above effects will result. (See Country List in ANNEX VII).

2) The new RIR must demonstrate that it has the broad support of the LIRs (ISPs community) in the proposed region.

The broad support of the LIR (ISP community) for the LACNIC region will be duly documented and presented during the course of the ARIN/LACNIC transition plan implementation.

A joint ARIN/LACNIC communiqué will be sent to all the current members of ARIN who belong to our region, informing them of the transition plan and including the new service agreement. (See ANNEX I).

3) Bottomup selfgovernance structure for setting local policies.

LACNIC has clearly documented defined procedures for the development of resource management policies.

LACNIC has developed and will develop their policies by means of the following proceedings in order to ensure a participative and open environment:

- An annual meeting will be held with free and open participation, wherein policies will be discussed. The meeting will also feature educational activities on related subjects that have to do with LACNIC.
- Annual national meetings will be organized for the discussion of policies, at least in those countries with significant usage of IP addresses.
- Marketing activities will be undertaken in order to stimulate participation of the region ISPs in the processes of discussing policies.
- There will be active mailing lists for the discussion of publicly filed policies, with free access.
- There will be public libraries available on the Internet containing the policy documents.

It should be mentioned, at this point, that LACNIC has already organized a promotional event under the name of LACNIC 2000, which brought

together a number of Internet stakeholders in the region.

The policies will be framed within the general objectives of IP registry systems, especially with regards to the conservation of IP address space, and the aggregation of routing information. These are and will be based on the internationally established standards, currently on documents such as RFC 2050 and the ASO MoU and the ICANN ICP2.

LACNIC considers itself able to assume responsibility for organizing the "Address Council General Assembly" in the region. As proof of the capability of LACNIC founding members to organize high level international events, we can mention:

- a. ICANN Meeting (Montevideo, 2001)
(<http://www.icann.org/montevideo/index.html>)
- b. ENRED Workshop, Walc 2001 (Venezuela, 2001)
(<http://www.walc2001.ula.ve>)
- c. II Latin American Electronic Commerce Summit (Buenos Aires, 2001)
(<http://www.ecomlac.org>)
- d. LACNIC 2000 (Buenos Aires, 2000) (<http://www.cabase.org.ar>)
- e. AHCINET III Regulation Summit (Mexico, 2000)
(<http://www.ahciet.net>)
- f. Internet AHCINET 2000 Forum (Santiago, 2000)
(<http://www.ahciet.net>)
- g. Internet AHCINET Commission Workshop (Santiago, 2000)
(<http://www.ahciet.net>)
- h. ENRED Workshop, Walc 2000 (Mexico, 2000)
(<http://www.walc2000.unam.mx>)
- i. I Latin American Electronic Commerce Summit (São Paulo, 2000)
(<http://www.ecomlac.org>)
- j. ICANN Meeting (Santiago, 1999)
(<http://www.icann.org/santiago/santiago-details.htm>)
- k. Internet AHCINET 1999 Forum (Buenos Aires, 1999)
(<http://www.ahciet.net>)
- l. Internet AHCINET Commission Workshop (Buenos Aires, 1999)
(<http://www.ahciet.net>)
- m. ENRED Workshop, Walc 99 (Venezuela, 1999)
- n. IFWP Latin America Meeting (Buenos Aires, 1998)
(<http://www.cabase.org.ar>)
- o. ENRED Workshop, Walc 98 (Rio de Janeiro, 1998)

4) Neutrality and impartiality in relation to all interested parties, and particularly the LIRs.

All customers of LACNIC will be treated equally. The LACNIC policies and guidelines ensure neutral and impartial distribution of resources and non/discriminatory treatment of all members and all requestors. LACNIC is incorporated as an independent, notforprofit and open bottomup membership organization, as defined in our bylaws. (See ANNEX II).

LACNIC General Structure is as follow:

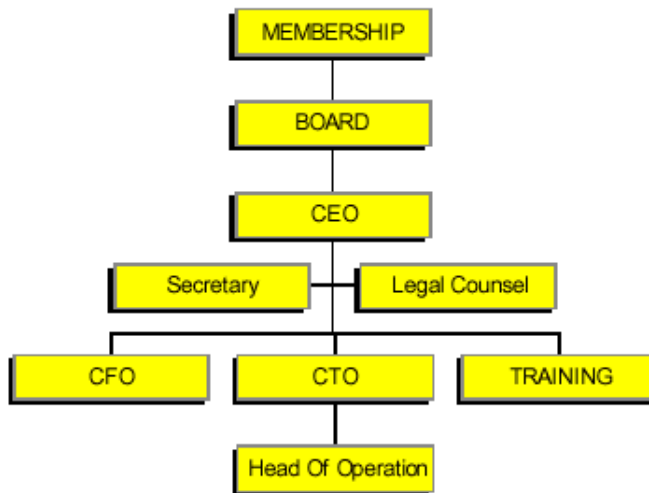

5) Technical expertise

LACNIC is clearly technically capable of providing the required allocation and registration services to our community. Specific technical requirements include the following provisioning:

- Production grade global Internet connectivity, in order to provide access to all services offered, and for the exchange of registry data to and from the other RIR whois database servers.
- DNS servers to support reverse DNS delegation.
- Suitable internal infrastructure for operational purposes for technically capable staff to ensure appropriate service levels to the LIR and to the Internet community.

The above points are illustrated in hereunder:

- Connectivity

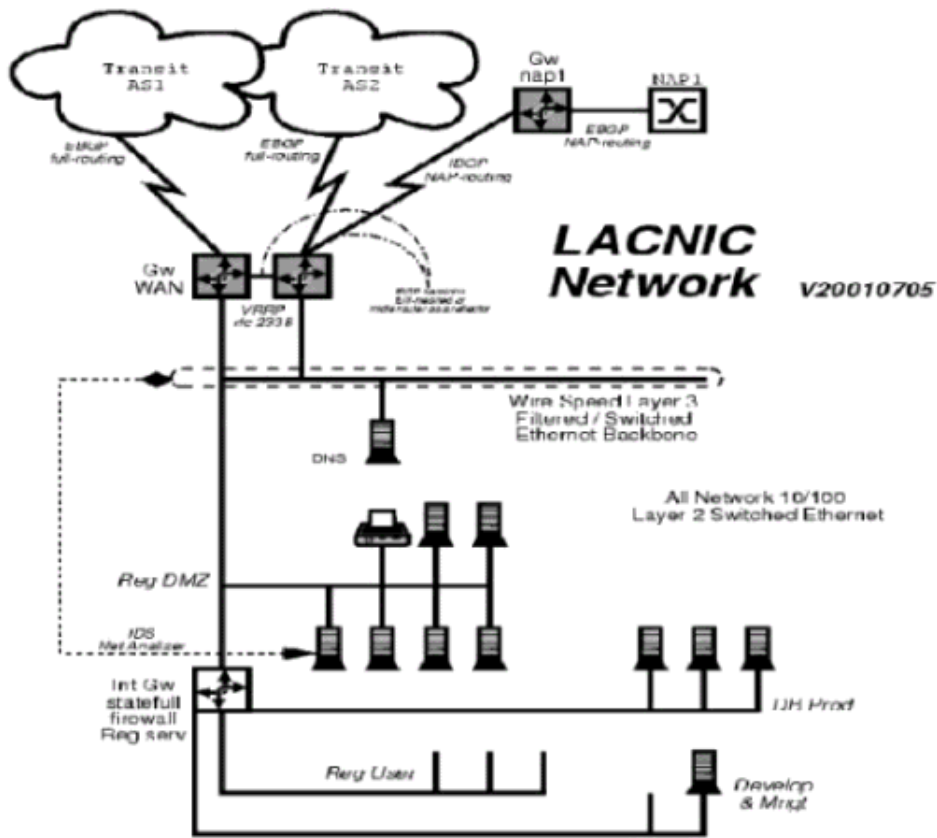

- Hardware and Software

Hardware based on Intel technology with physical redundancies for all the services.

Software for the registry services, information and publication of reverse DNS, based on objects with persistence technology maintained in a relational database with SQL interface. All the software works on open operating systems (OS).

- Technical Profile

The teams who handle operations, user helpdesk and engineering are technical personnel, highly qualified by extensive experience in the administration of Internet resources. (See Resumes in ANNEX V).

- Operations Organizational Chart

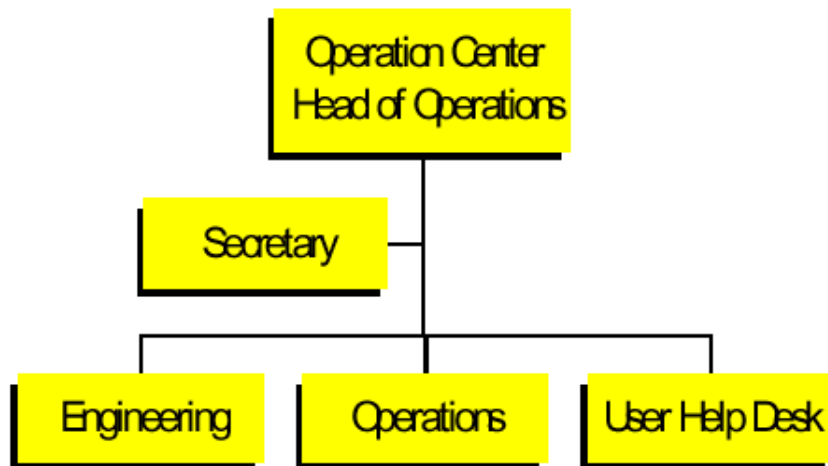

6) Adherence to global policies regarding address space conservation, aggregation and registration

LACNIC has established policies that ensure the main goals of the registry system, in particular conservation of IP address space and aggregation of routing information.

Local policies are developed in addition to established global policies to be consistent with this and other global policy goals. (see LACNIC Policies in ANNEX III).

LACNIC declares that our policies are fully documented and publicly accessible. Further more we reconfirm our intent to become a signatory of the MoU and ICANN RIR contract.

Since 2000, LACNIC has attended Address Council meetings through one observer and 2 listeners. LACNIC has attended and make presentations at ASO General Assemblies, ASO AC workshops, at meetings of the RIRs.

7) Activity plan

LACNIC provide following continuing activities that are with the purview of an RIR and which are explicitly supported by our community organization.

7.1 Operational Aspects

7.1.1 Independence

Due to the agreement signed between LACNIC and Brazil, the initial operation will be realized in the FAPESP installations in Sao Paulo. At this time FAPESP is in charge of the operations of NIC Brazil and the ccTLD .br registry. These tasks are carried out under the responsibility of the Comitê Gestor Internet do Brasil (CGIBR).

In the above mentioned agreement, LACNIC established the requirement that the entire operation should be absolutely independent from the routine activities of FAPESP, NIC Brazil and the .br registry.

The installations have been done according to what has been scheduled and to LACNICs satisfaction.

Currently, the installations available for the LACNIC operation include independent servers, independent communications equipment, independent connectivity services, and also physical locations separate from the rest of the equipment available in the same organization.

The technical staff that will work in the LACNIC operations tasks will also be independent, and will be dedicated exclusively to the LACNIC specific functions.

7.1.2 Future site change

The Comitê Gestor Internet do Brazil (CGIBR) foresees move this year to new premises. As from that time, they will directly absorb the administration of all tasks related to the NIC Brazil and the .br registry, which are currently done in FAPESP.

It is also foreseen that at that time, LACNIC will also install their operations center in this new building, where the same independence conditions will prevail for the correct LACNIC functioning.

The change of site will be done in planned stages, without any interruption to services.

7.1.3 Supervision

The initial LACNIC operation model is similar to an outsourcing agreement with special characteristics, since it will not cost LACNIC anything, and will thus be a fundamental contribution to the startup of the organization, without large initial investments.

Thus, the operations staff will be under the contractual responsibility of the NIC Brazil.

LACNIC will technically supervise their functions. The LACNIC Technical Manager will be the person who will be working in coordination with the Operations Manager to ensure fulfillment of LACNIC policies, ensure the quality of customer service and attend the procedures for continuous improvement.

The Technical Manager will be the link between the LACNIC Board and the Operations staff, which ensures LACNICs absolute independence. This position is currently occupied by Julian Dunayevich.

7.2 Installation of the LACNIC offices in Montevideo

7.2.1 Roles

LACNIC will be an organization legally established in Uruguay, and thus the administrative and financial tasks will be done from this office in Montevideo, which will be responsible for administrative communications with members, issuing receipts and invoices, collections and payment to suppliers.

7.2.2 Infrastructure

Initially a small office with the necessary communications services will be established.

7.2.3 Human Resources

As from initiation of LACNIC operations in the block assignments with second opinion of ARIN period, a CFO will be in place who will undertake all administrative and financial tasks together with a legal counsel.

As from the final recognition of ICANN, the hiring of a secretary and a CEO, who will report to the Montevideo Office even though his tasks will be shared out between Montevideo and São Paulo as well as necessary travel to other cities, is foreseen.

Initially, and until the appointment of a CEO, the Board and its Chair will be responsible for the management of the Montevideo Office.

7.3 Members' fees and payments

Initially, the members fees and payments will be identical to those ARIN applies, and this will be maintained as a minimum until the time of final recognition from ICANN.

7.4 Transition Plan

As from the work meetings between LACNIC and ARIN, an operations transition has been agreed upon which will be divided into 3 phases.

Phase 1

Activities in this phase include:

- Training at ARIN for LACNIC registration personnel
- Technical Interchange meetings between ARIN and LACNIC engineering staffs.
- Onthejob training of LACNIC registration personnel. Under ARIN supervision, LACNIC personnel will process all LACNIC region requests that are received by ARIN.
- LACNIC legal counsel will devise the Registration Service Agreement (RSA). The ARIN RSA will be used as a basis and revised to reflect the requirements of the contract law of Uruguay.

This phase will conclude when LACNIC personnel have processed sufficient resource requests to demonstrate competence. For planning purposes this has been determined to be equal to the quarterly average of LACNIC area requests received by ARIN for the past two (2) years.

Phase 2

This will begin immediately after Phase 1 is completed.

- LACNIC will receive the resource requests which will be evaluated by the LACNIC technical/operations staff. ARIN will perform a second opinion evaluation of all registration actions.
- Administration functions of LACNIC will begin. Registration Service Agreements will be executed, invoices will be issued, and payments will be processed.
- The Registry data shall be kept simultaneously in the LACNIC and ARIN databases, in order to ensure continuity of service if unforeseen circumstances arise.
- LACNIC will establish the reverse DNS servers for the subdomains of in addr.arpa and ip6.arpa.

This phase will conclude when:

- LACNIC personnel have processed sufficient resource requests to demonstrate competence. For planning purposes this has been determined to be equal to the quarterly average of LACNIC area requests received by ARIN for the past two (2) years.
- All administrative and business functions are fully operational.

Phase 3

Final recognition of LACNIC by ICANN.

- LACNIC will apply its own policies and procedures.
- LACNIC records will be removed from the ARIN database.
- ARIN technical and operations staff will provide mentoring support to LACNIC

as requested by LACNIC.

7.5 Initial Authorities

The Board shall be made up of the following people, representing each of the founding organizations:

- § Raul Echeberria (ENRED) Chair
- § German Valdez (NIC Mexico) Secretary
- § Oscar Messano (CABASE) Treasurer
- § Hartmut Glaser (CGIBR) Director 1
- § Raimundo Beca (AHCJET) Director 2
- § Fabio Marinho (ECOMLAC) Director 3

It is the intention of the LACNIC founding members to deliver control of LACNIC to its members as soon as the organization and membership have been consolidated. Thus, in article 34 of the bylaws, the procedures covering the stages of incorporation of new directors and the replacement of the current ones, are included. The first election of 3 Directors will take place one year from the constitution of LACNIC.

In addition to registration services, LACNIC also provide technical training, public mailing list maintenance, information services, database services, meetings organization, general liaison and coordination tasks. These activities will cover both the basic principles of RIR and subject of interest of the members.

LACNIC has defined the following objectives for their activity:

- To administer the IP address space and other associated resources on behalf of the Internet community in Latin America and the Caribbean.
- To provide the services of registration of IP addresses, ASN, inverse resolution and their associated resources, for the purpose of permitting and facilitating communications by means of computer networks.
- To collaborate with the growth of the Internet in the region.
- To assist the Latin American and Caribbean community in the development of procedures, mechanisms and standards for the efficient assignment of Internet resources.
- To promote educational opportunities for its members in technical and political areas within its charter.
- To propose and develop the public policies in within the scope of its charter.

Due to the difference of DNS and Internet resource related functions, LACNIC guarantees it will not undertake any activities related to domain name assignment and/or registration.

8) Funding model

LACNIC is established as a nonfor profit organization incorporated under Uruguayan Laws. Due to the agreement signed between LACNIC and The Brazilian Internet Steering Committee (CGIBR) the operations center will be installed in their own facilities in São Paulo Brazil. The above agreement establishes that the entirely operation will be sponsored by CGIBR for a term of two years. The operation costs include infrastructure and staff in São Paulo.

Initial sponsorship from CGIBR guarantees the funding of the Operational Center in São Paulo for the next two years others grants, donations and fees coming from the customers provide the budget for other activities. The yearly budget will be published and discussed in our member meetings, which will afford demonstrable support of our community. (see Funding Model in ANNEX IV).

LACNIC has decided to use the following fee structure for its services:

IPv4 Allocation Services

Category	Fee US\$ Annually	Allocation Size
Small	2,500	/24- /19*
Medium	5,000	>/19 - /16
Large	10,000	>/16 - /14
X-Large	20,000	> /14

IPv4 Assignment Services

Category	Fee US\$	Assignment Size
Small	2,500	/24 - /19
Medium	5,000	/18
Large	7,500	/17
X-Large	10,000	/16

IPv6 Services

Category	Fee US\$ Annually	Allocation Size
Regular	25,000	/35
Large	20,000	>/35

ASN Services

Concept	Fee US\$
Assignment	500
Renewal (yearly)	30

Transfer Services

Concept	Fee US\$
Transfer	250

9) Record Keeping

LACNIC declares it will maintain proper records of all registry activities, including the archiving of all information collected from LIRs in the process of making IP address space assignments. This data will be used for the evaluation of subsequent requests from the same customers and to permit the operational audit of LACNIC operations, in order to demonstrate responsible and neutral operations.

LACNIC official registration language will be English.

Therefore all the relevant archives and records which may be subject to frequent review by other RIRs, IANA or ICANN will be available at all times in English. Any other information that may be required for operational audit of LACNIC procedures will be provided in English within 10 working days.

LACNIC proposes to make the following auditable procedures for registry record keeping in English, by means of:

- LACNIC Website
- Policies
- Bylaws
- Annual reports
- Whois DB
- Templates
- Financial documents
- Board meeting minutes
- Public meeting minutes.

10) Confidentiality

All information that LACNIC receives from customers will be kept under strict norms of confidentiality and used for registration purpose only. In case of information is requested about a customer by another RIR or IANA, LACNIC will transmit this information under the same confidentiality agreement, but will not be transmitted to any other party unless explicitly agreed to in writing by the RIR/ISP served.

LACNIC establishes herein that Board Members are not allowed to participate in discussions where there are conflicts of interest. All board members and staff members are required to sign nondisclosure statements (see ANNEX VI LACNIC Non disclosure agreements).

Annexes

Annex I	- LACNICs Service Agreement Letter. (http://lacnic.org/docs/rsa-en.pdf)
Annex II	- LACNICs Bylaws. (http://lacnic.org/en/by_laws.html)
Annex III	- LACNICs Policies. (http://lacnic.org/en/policies.html)
Annex IV	- LACNICs Funding Model.
Annex V	- LACNICs Staff Resumes.
Annex VI	- LACNICs Non Disclosure Agreements. (http://lacnic.org/docs/nda-en.pdf)
Annex VII	- LACNICs Country List. (http://lacnic.org/en/list.html)